

# Centrifugal Liquid Hydrogen Pump

## LHC/LHR Model

\*The "○○○ type" in the catalog LHC/LHR Model is our model symbol



The products listed in this catalog fall under the category of "goods indicated in Export Trade Control Order Appended Table 1, item 16." Therefore, when exporting them it will be necessary to confirm information such as their "Application" and "User," and in some cases permission from the Minister of Economy, Trade and Industry will be required. (These requirements should be confirmed by the exporter.)

Contact for inquiries:  
Email: [hydrogen@ebara.com](mailto:hydrogen@ebara.com)



\*Some content of the catalog may be revised due to product improvements. We appreciate your understanding in advance. \* "Model○○○" in this catalog is our model code.  
\*Reproduction of the content of this catalog without permission is prohibited.  
The listed products fall under the category of "goods indicated in Export Trade Control Order Appended Table 1, item 16." Therefore, when exporting them it will be necessary to confirm information such as their "Application" and "User," and in some cases permission from the Minister of Economy, Trade and Industry will be required. (These requirements should be confirmed by the exporter.)



## Contributing to the Hydrogen Supply Chain

Demand for Hydrogen has been increasing recently as a substance that can contribute to the decarbonization efforts, across multiple industries and sectors. In order for its application to society, Hydrogen must be produced, transported and distributed on a large scale.

Among the various modes of transportation of Hydrogen, Liquid Hydrogen (LH2) is attracting attention for its transportation efficiency.

And we at Ebara Corporation aim to contribute to the ever expanding Hydrogen supply chain and building a net-zero society by providing a safe and efficient means of transportation with our LH2 Pumps.

## Overcoming the Challenges in Development

Liquid Hydrogen(LH2) needs to be kept at an extreme temperature of below  $-253^{\circ}\text{C}$  in order to prevent gasification.

Furthermore, its density is only 1/6 of that compared to LNG and also can embrittle most materials.

Our development efforts have been centered upon developing a pump which can overcome such extreme liquid properties and at the same time ensuring a safe, long-term usage of our equipment under these conditions.

We have verified this through trial runs using actual LH2 and aim to continue our development for a wider range of products applicable for larger capacities and higher pressure.

## Our Products can Serve Various Industries

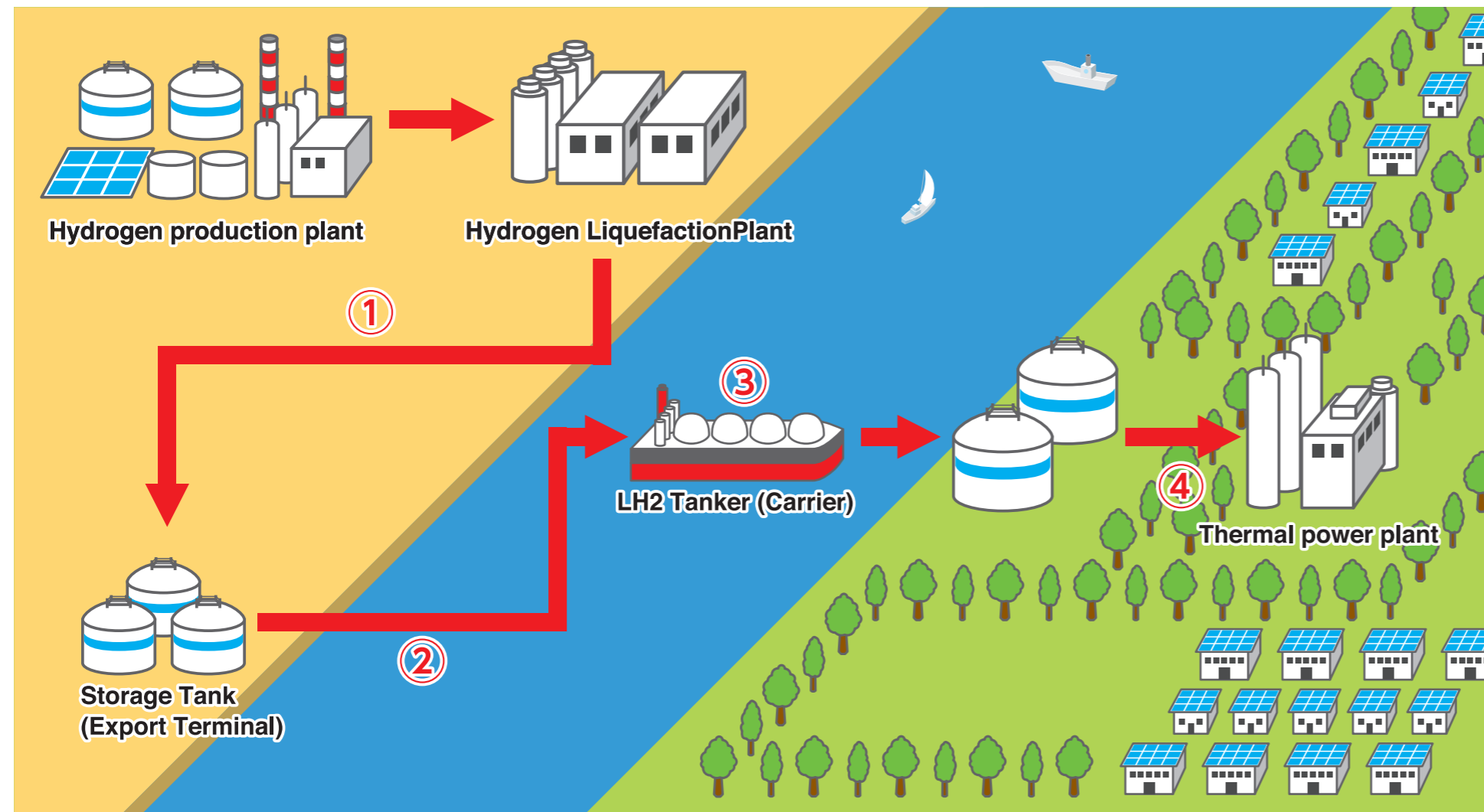

- (1): We can transport the produced liquid Hydrogen quickly and efficiently to the export terminal or other required locations using our liquid hydrogen pumps. Our vacuum-insulated pot type pump design can ensure to prevent gasification of the liquid Hydrogen during the transport process.
- (2): Our LH2 pumps can serve a wide range of requirements when it comes to the export stage of Liquid Hydrogen from the export terminal by matching the required flow, pressure and tank design.
- (3): With the goal to contribute to all aspects of the Hydrogen supply chain, we are also focusing our R&D efforts towards the development of in-tank export pumps and cooling pumps for LH2 Tankers.
- (4): In the final stage of distribution and usage, our pumps can transport liquid hydrogen from the storage tanks of the receiving facilities to the required end destination. Not only that, our products can serve various industries & applications such as LH2 Power plants, steel mills and other chemical industries for the actual usage.

# Liquid Hydrogen Booster Pump

The world's first centrifugal liquid hydrogen fuel supply pump

## Structure

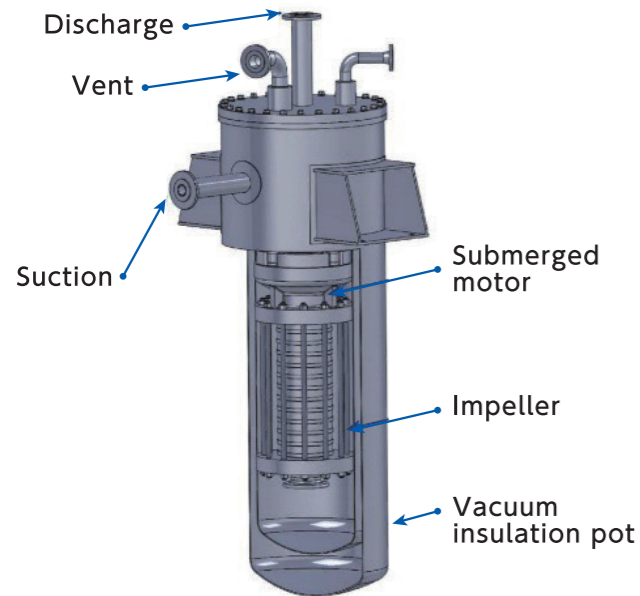

## Features

- Pot-in multistage type pump
- Vacuum-Insulation Pot
- Cryogenic convertible: 20K (-253°C)

## LH2 operation test

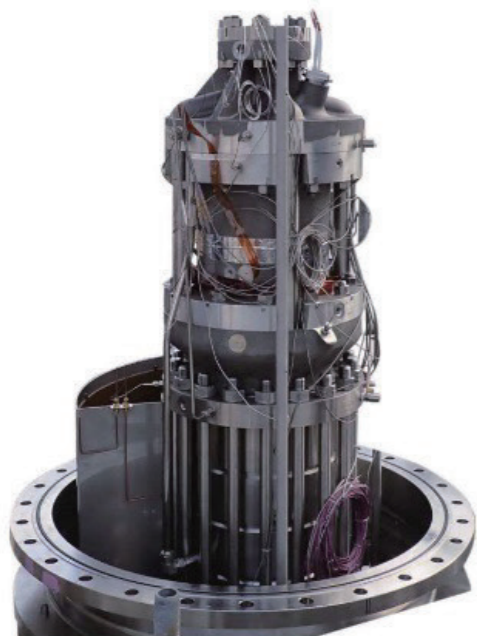

Prototype of LH2 pump

## Application



Liquid hydrogen power generation



Liquid hydrogen receiving terminal

\*The above photos are for reference

# In-tank Type Liquid Hydrogen Booster Pump

Suitable solution for liquid hydrogen storage by PC tank

## Structure

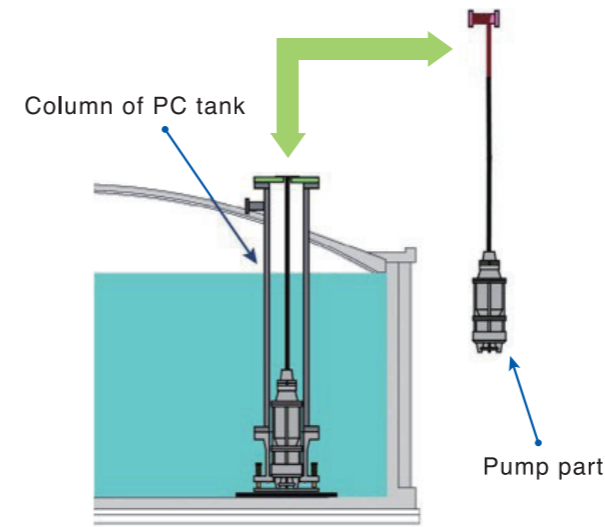
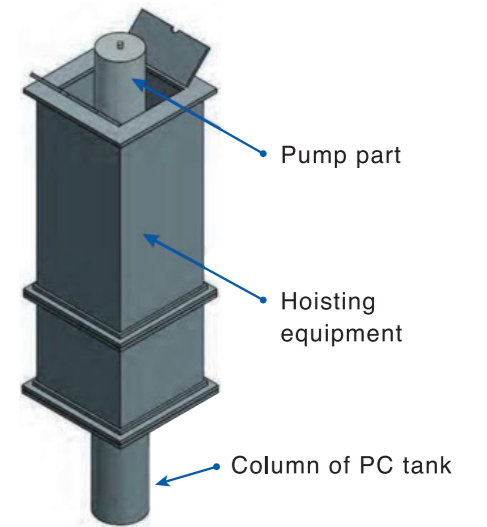

Image of pump attachment and detachment to the PC tank



Hoisting equipment image (under development)

## Features

- In-tank type liquid hydrogen centrifugal pump
- Safe installation and maintenance by using dedicated equipment
- Designed to prevent leakage and contamination of liquid hydrogen

## Application



Transporting liquid hydrogen



Liquid hydrogen receiving terminal

\*\*The above photos are for reference

## Pump Performance

- Head (0.2 MPaG to 5 MPaG) <sup>\*1</sup>
- Flow rate (~900m<sup>3</sup>/h) <sup>\*1</sup>
- Manufacturing site  
(Ebara Corporation, Futtsu Plant)

\*1 Please contact us for items outside the range.



Ebara Corporation, Futtsu Plant



## Application example : Use at a liquid hydrogen exporting terminal

### Liquid hydrogen exporting terminal process flow chart

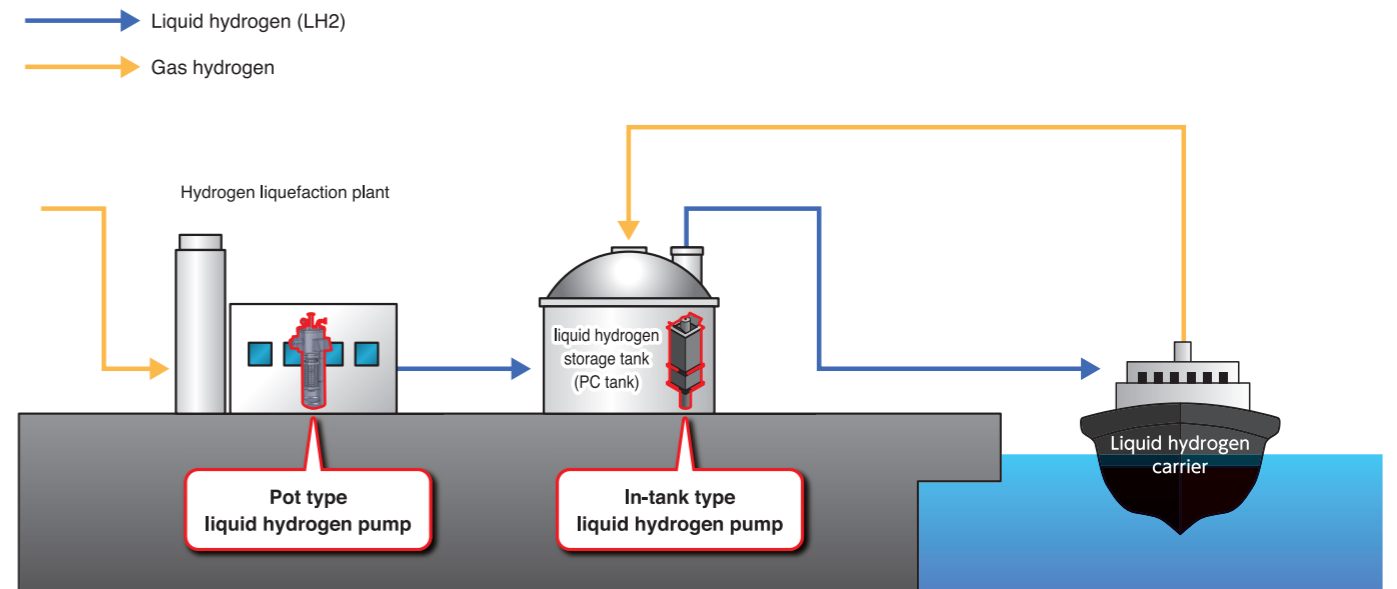

## Application example : Use at liquid hydrogen receiving terminal and hydrogen power plant

### Process flow diagram: Receiving of liquid hydrogen to supply of fuel hydrogen for power generation

