



EBARA

PROCESS PUMP

Single Stage, End Suction, Foot Support

CS1150EQ

Model

IFW

ISO 2858

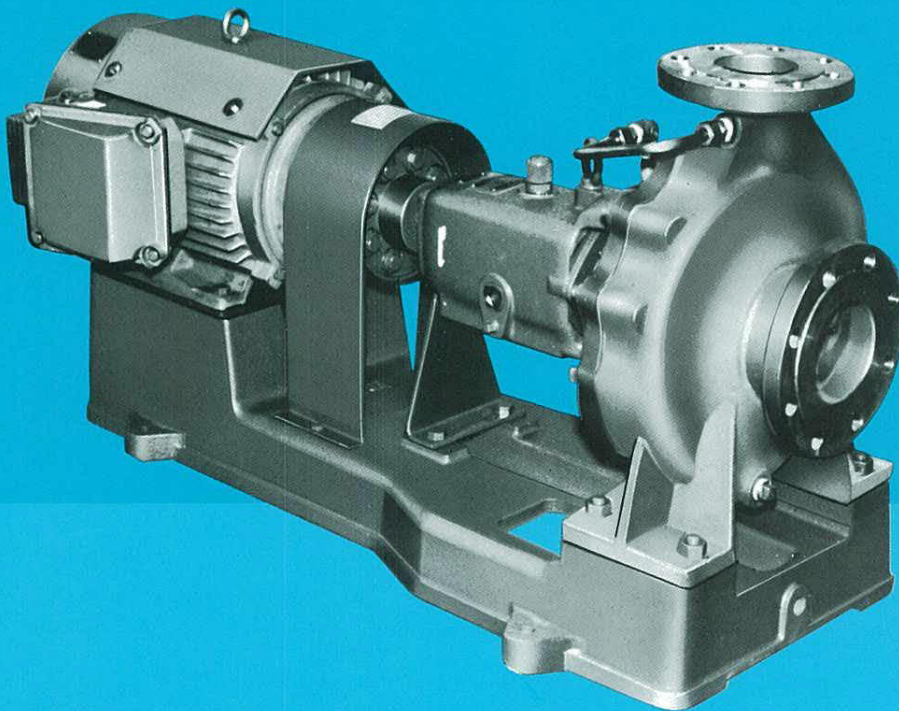

PROCESS PUMP

Single Stage, End Suction, Foot Support

Model

IFW

ISO 2858 

EBARA PROCESS PUMPS MODEL IFW of single stage, end suction, foot supported, horizontal type have been widely used in the chemical industry, petroleum refineries, the petrochemical industry and other industries

for many years. Many improvements have been recently made on this pump to enhance its performance. "The money saver" Our modern mass production facilities enable us to pass the cost-savings on to you. Unique

design of this high performance pump features stainless steel, cast steel casing or cast iron for superior and extended low-cost operation.

Applications

- Chemical Industry
- Petroleum Refineries
- The Petrochemical Industry
- Other Industries

Ratings

Capacities	To 24 m ³ /min (3700 USGPM)
Heads	To 140 m (470 ft)
Discharge pressures	To gauge pressure 1.57MPa(230PSI) {16kgf/cm ² }
Max. allowable suction pressures	To gauge pressure 0.88MPa(130PSI) {9kgf/cm ² }
Hydrostatic test pressures	To gauge pressure 2.3MPa(340PSI) {24kgf/cm ² }
Speed	50 Hz 1450 or 2950 min ⁻¹ 60 Hz 1750 or 3550 min ⁻¹
Max. allowable speed	To 3600 min ⁻¹
Rotation	Clockwise viewed from inboard side
Impeller type	Enclosed
Temperatures	Stainless steel: -50°C to 200°C (-58°F to 392°F) Cast steel: -5°C to 200°C (-23°F to 392°F) Cast iron: -15°C to 150°C (-5°F to 300°F)
Flange rating	JIS10KRF/ANSI 150 RF (Stainless steel, Cast steel) JIS10KFF/ANSI 125 FF (Cast Iron)
Nozzles	End-Top
Stuffing box	Suitable for conventional packing & mechanical seal

Features

- Foot support and heavy duty design.
- Back pull-out casing.
- Full compliance with ISO 2858 specifications.
- All components have been designed for maximum parts interchangeability.
- Flexibility of design handles wide range of liquids.
- All sizes stocked for fast shipment.
- Low NPSH performance.

Wide-Range for Best Choice!!



Availability in modules provides complete interchangeability of components between different types and permits pump selections best suited for the given specifications.

	Bearing casting	Shaft	Gland cover	Impeller	Casting	Pump model designation
Bearing Group I						40×25-1312
						40×25-1612
						40×25-2013
Bearing Group II						50×40-1323
						50×40-1623
						50×40-2013
						50×40-2524
						80×50-1313
						80×50-1623
						80×50-2023
Bearing Group III						4P 80×50-3214
						2P 80×50-3224
						100×80-1314
						100×80-1614
						100×80-2024
						100×80-2524
						100×80-3215
						150×100-1614X
						150×100-2015X
						4P 150×100-2525X
Bearing Group IV						2P 150×100-2515XA
						4P 150×100-3225X
						2P 150×100-3215XA
						4P 150×100-4015X
						150-2015Y
						150-2515Y
						150×100-3225Y
						150×100-4025Y
						150×100-5016Y
						200-2015
Bearing Group VI						200-2515
						200×150-3216
						200×150-4026
						200×150-5028
Bearing Group VII						250-2516
						250×200-3216
						250×200-4016
						250×200-5028

Selection Chart



50Hz

2pole [Synchronous speed : 3000min⁻¹]

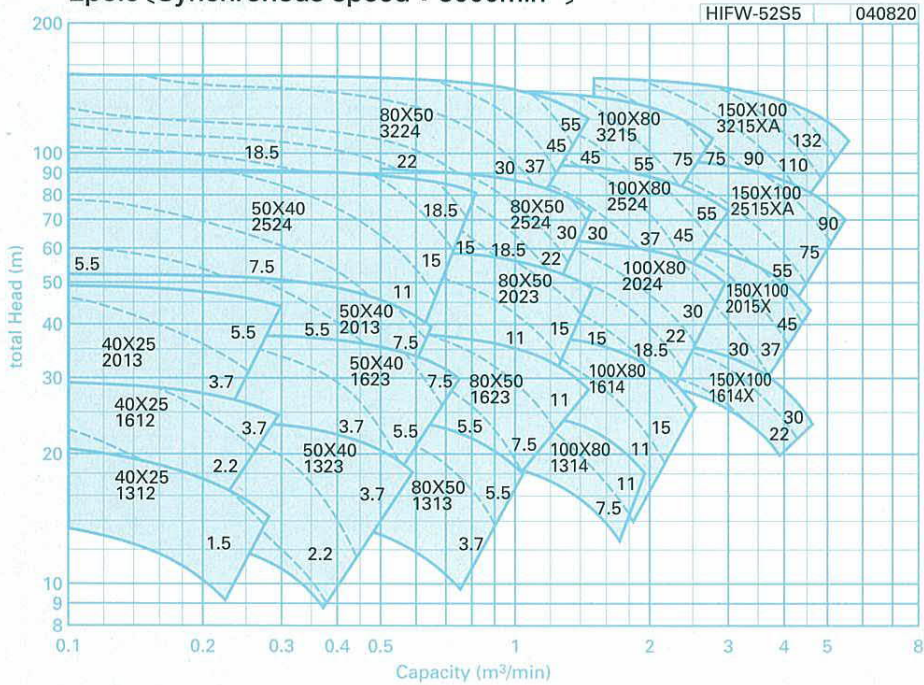

4pole [Synchronous speed : 1500min⁻¹]



Selection Chart



60Hz

2pole [Synchronous speed : 3600min⁻¹]

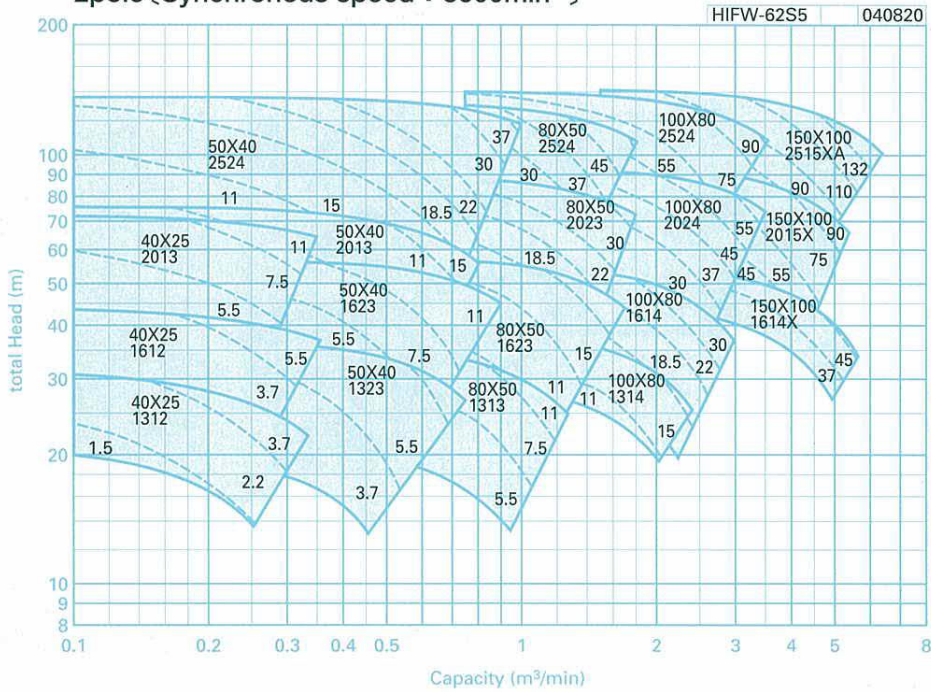

4pole [Synchronous speed : 1800min⁻¹]

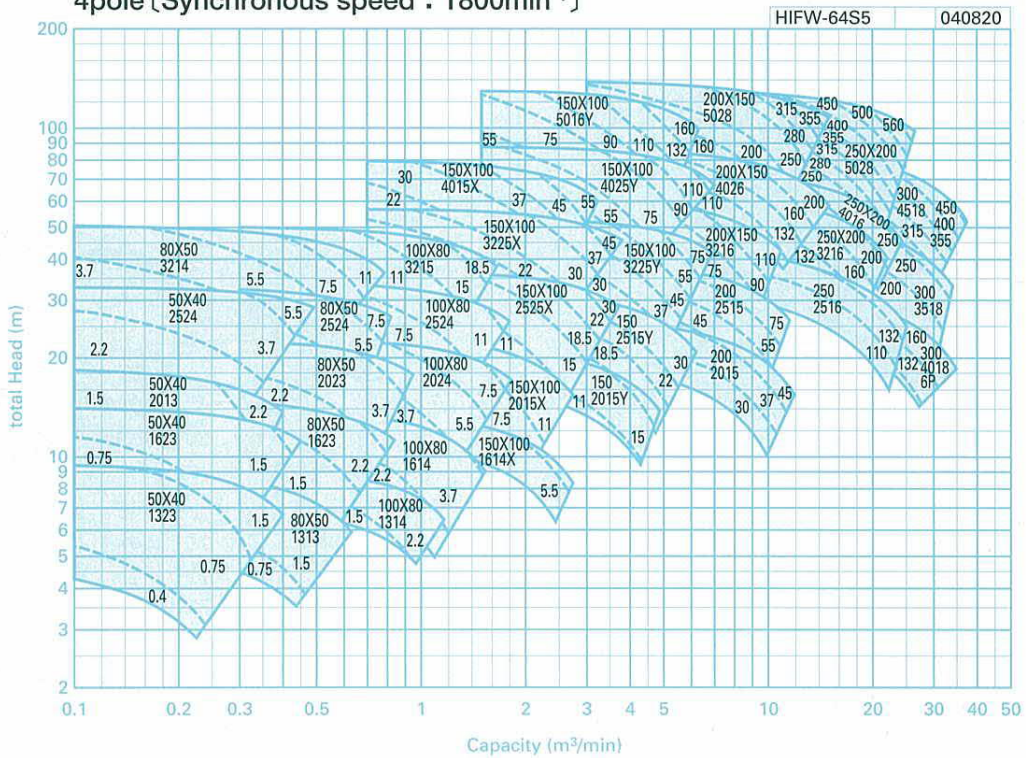

Construction



Sectional Drawing of Standard Type (Cast Iron)

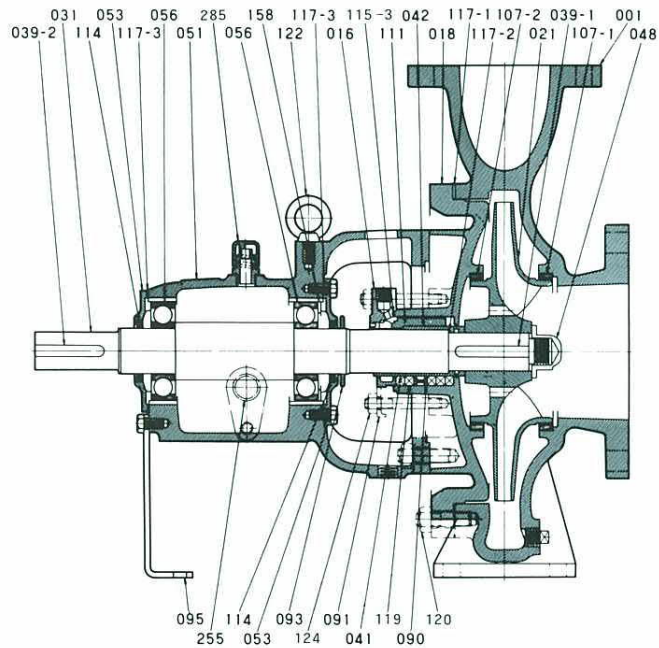

Part List

No.	Name of part	Material		Quantity
		Cast iron	Ductile cast iron	
001	Casing	FC250	FCD	1
016	Mechanical seal cover	SUS304	SUS304	1
018	Gland cover	FC250	FCD	1
021	Impeller	FC200	FC200	1
031	Shaft	S35C	S35C	1
039-1	Impeller key	S50C	S50C	1
039-2	Coupling key	S50C	S50C	1
041	Packing sleeve	SUS403	SUS403	1
042	Mechanical seal sleeve	SUS316	SUS316	1
048	Impeller nut	S30C	S30C	1
051	Bearing casing	FC200	FC200	1
053	Bearing cover	FC200	FC200	2
056	Ball bearing	—	—	2
066	Cooling cover	FC200	FC200	1
090	Lantern ring	SUS304	SUS304	1
091	Packing gland	FC150	FC150	1
093	Flinger	SUS304	SUS304	1
095	Stay	SS400	SS400	1
107-1	Liner ring	FCD400	FCD400	1
107-2	Liner ring	FCD400	FCD400	1
111	Mechanical seal	—	—	1
114	Oil seal	SPHC/NBR	SPHC/NBR	2
115-3	O-ring for mechanical seal cover	Teflon	Teflon	1
117-1	Gasket for casing	V#6500	V#6500	1
117-2	Gasket for shaft sleeve	V#6500AC	V#6500AC	1
117-3	Gasket for bearing cover	OIL SHEET	OIL SHEET	1
117-4	Gasket for cooling cover	NBR	NBR	2
119	Gland packing	P#6501L	P#6501L	5
120	Casing bolt	SS400/SUS403	SS400/SUS403	1 set
122	Hook bolt	S20C	S20C	1
124	Gland bolt	SUS403	SUS403	2,4
158	Wave washer	SK5	SK5	1
255	Oil level gauge	Synthetic rubber/Glass	Synthetic rubber/Glass	1
285	Air Breather	Polycarbonate	Polycarbonate	1

Bearing Casing with Cooling Jacket

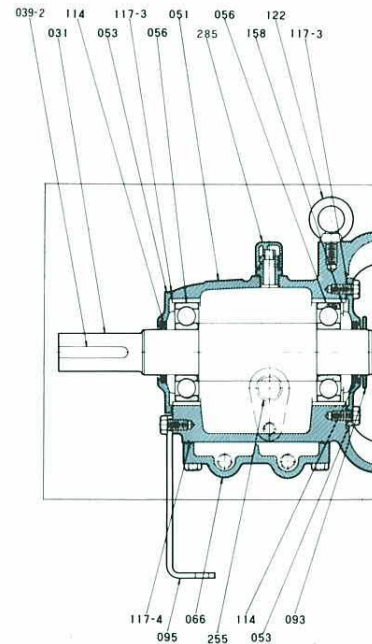

(Note) 1. Combinations of parts in other materials than listed are also available upon request.

2. Packing/gasket material letters is as following.

P: Nippon Pillar made.
V: Nippon Valqua made.

Construction



Sectional Drawing of Standard Type (Stainless steel, Cast steel)

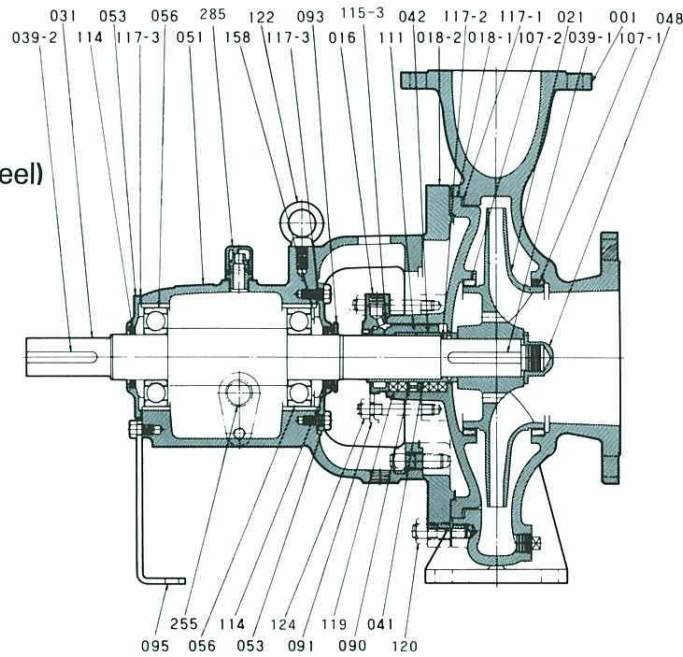

Stuffing Box with Cooling Jacket

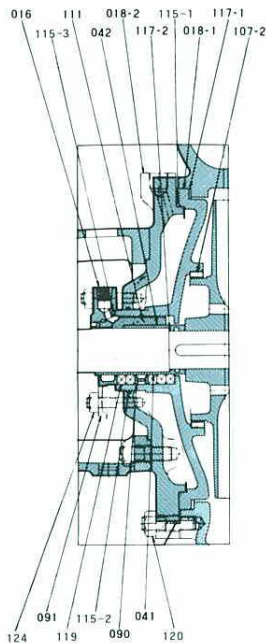

(Note) Stuffing box with Cooling Jacket is available with stainless steel and cast steel pumps only.

Part List

No.	Name of part	Material			Quantity
		Stainless steel	Cast steel		
001	Casing	SCS14	SCS13	SC480	1
016	Mechanical seal cover	SUS316	SUS304	SUS304	1
018-1	Gland cover (I)	SCS14	SCS13	SC480	1
018-2	Gland cover (II)	FCD400	FCD400	FCD400	1
021	Impeller	SCS14	SCS13	FC200	1
031	Shaft	SUS316	SUS304	S35C	1
039-1	Impeller key	SUS316	SUS316	S50C	1
039-2	Coupling key	S50C	S50C	S50C	1
041	Packing sleeve	SUS316	SUS304	SUS420J1	1
042	Mechanical seal sleeve	SUS316	SUS304	SUS403	1
048	Impeller nut	SUS316	SUS304	S30C	1
051	Bearing casing	FC200	FC200	FC200	1
053	Bearing cover	FC200	FC200	FC200	2
056	Ball bearing	—	—	—	2
066	Water-cooling cover	FC200	FC200	FC200	1
090	Lantern ring	SUS316	SUS304	SUS304	1
091	Packing gland	SCS14	SCS13	FC150	1
093	Flinger	SUS316	SUS304	SUS304	1
095	Stay	SS400	SS400	SS400	1
107-1	Liner ring	SUS316	SUS304	FCD400	1
107-2	Liner ring	SUS316	SUS304	FCD400	1
111	Mechanical seal	—	—	—	1
114	Oil seal	SPHC/NBR	SPHC/NBR	SPHC/NBR	2
115-1	O-ring for gland cover	NBR	NBR	NBR	1
115-2	O-ring for gland cover	NBR	NBR	NBR	1
115-3	O-ring for mechanical seal cover	Teflon	Teflon	Teflon	1
117-1	Gasket for casing	V#6500AC	V#6500AC	V#6500AC	1
117-2	Gasket for shaft sleeve	V#6500AC	V#6500AC	V#6500AC	1
117-3	Gasket for bearing cover	OIL SHEET	OIL SHEET	OIL SHEET	2
117-4	Gasket for water-cooling cover	NBR	NBR	NBR	1
119	Gland packing	P#6501L	P#6501L	P#6501L	5
120	Casing bolt	SUS403	SUS403	SUS403	1 set
122	Hook bolt	S20C	S20C	S20C	1
124	Gland bolt	SUS316	SUS304	SUS403	2, 4
158	Wave washer	SK5	SK5	SK5	1
255	Oil level gauge	Synthetic rubber/glass	Synthetic rubber/glass	Synthetic rubber/glass	1
285	Air Breather	Polycarbonate	Polycarbonate	Polycarbonate	1

(Note) 1. Combinations of parts in other materials than listed are also available upon request.
2. Packing/gasket material letters is as following.
P: Nippon Pillar made.
V: Nippon Valqua made.

Shaft Sealing System



	A	B	C
1	<p>1A Balanced seal (Standard type)</p>	<p>1B Balanced seal (Quench type)</p>	<p>1C Double seal (Open air-side balanced type)</p>
2	<p>2A Unbalanced seal (Standard type)</p>	<p>2B Unbalanced seal (Quench type)</p>	<p>2C Double seal (Open air-side unbalanced type)</p>
3	<p>3A Metal bellows (Standard type)</p>	<p>3B Mono Coil Seal</p>	<p>3C Outside seal</p>
4	<p>4A Gland packing (Standard type)</p>	<p>4B Gland packing (Quench type)</p>	<p>1. Dimensions of the shaft sealing packing box are subject to ISO-3069. Mechanical seal is standardized to DIN 24690 in type and dimensions.</p> <p>2. Other shaft sealing systems are available to meet different service requirements.</p>

Dimensions

Beo
Model-IFW

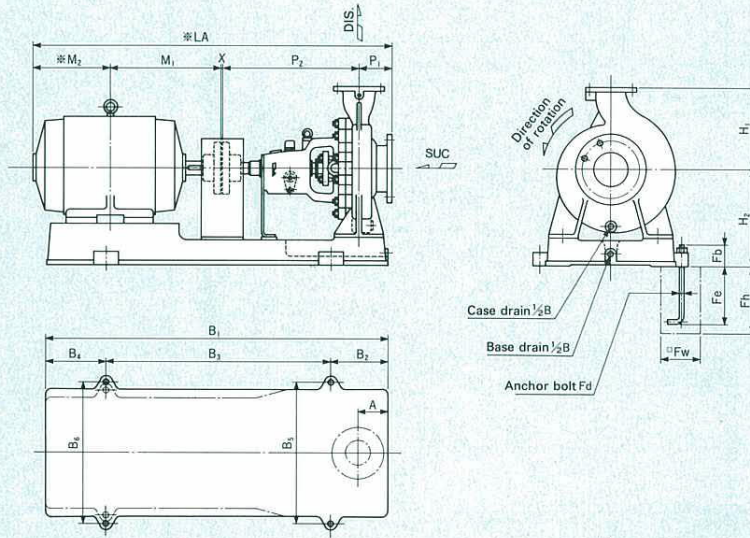

● Flange dimensions (JIS 10K, Regular flanges) for cast iron, cast steel and stainless steel pumps.

Unit: mm

Pump Model	Motor		Pump				Common base					Motor		* LA	X	Anchor bolt				Wt (kg)	Coupling					
	Frame	kW	P ₁	P ₂	H ₁	H ₂	A	B ₁	B ₂	B ₃	B ₄	B ₅	B ₆			M ₁	#M ₂	F _d	F _b		F _e	F _h	F _w	CLA	CLAB	
40×25 IFWM	80	0.75	80	385	160	212	60	725	115	480	130	290	250	140	133	741	3	M12	55	195	250	110	64	112	4-10	
	1312	90L	1.5/2.2	80	385	160	222	60	725	115	480	130	290	250	168.5	158.5	795	3	M12	55	195	250	110	64	112	4-10
40×25 IFWM	112M	3.7	80	385	160	212	60	765	130	540	95	320	320	200	183	851	3	M12	55	195	250	110	69	112	4-10	
	1612	132S	5.5/7.5	80	385	160	240	60	805	130	540	135	350	350	239	210	917	3	M12	55	195	250	110	71	140	6-14
40×25 IFWM	112M	3.7	80	385	180	240	60	765	130	540	95	320	320	200	183	851	3	M12	55	195	250	110	83	112	4-10	
	2013	132S	5.5/7.5	80	385	180	240	60	805	130	540	135	350	350	239	210	917	3	M12	55	195	250	110	81	140	6-14
	160M	11.5	80	385	180	255	60	970	170	660	140	400	400	323	280	1071	3	M12	55	195	250	110	101	140	6-14	
50×40 IFWM	71	0.4	80	385	160	212	60	725	115	480	130	290	250	120	121	709	3	M12	55	195	250	110	70	112	4-10	
	1323	80	0.75	80	385	160	212	60	725	115	480	130	290	250	140	133	741	3	M12	55	195	250	110	69	112	4-10
50×40 IFWM	90L	1.5/2.2	80	385	160	222	60	725	115	480	130	290	250	168.5	158.5	795	3	M12	55	195	250	110	69	112	4-10	
	1623	112M	3.7	80	385	160	212	60	765	130	540	95	320	320	200	183	851	3	M12	55	195	250	110	74	112	4-10
		132S	5.5/7.5	80	385	160	240	60	805	130	540	135	350	350	239	210	917	3	M12	55	195	250	110	76	140	6-14
	160M	11.5	80	385	160	255	60	970	170	660	140	400	400	323	280	1071	3	M12	55	195	250	110	95	140	6-14	
50×40 IFWM	80	0.75	100	385	180	240	60	725	115	480	130	320	250	140	133	761	3	M12	55	195	250	110	82	112	4-10	
	2013	90L	1.5	100	385	180	250	60	725	115	480	130	320	250	168.5	158.5	815	3	M12	55	195	250	110	83	112	4-10
		100L	2.2	100	385	180	240	60	765	130	540	95	320	320	193	173	854	3	M12	55	195	250	110	85	112	4-10
	132S	5.5/7.5	100	385	180	240	60	805	130	540	135	350	350	239	210	937	3	M12	55	195	250	110	86	140	6-14	
		160M	11.5	100	385	180	255	60	970	170	660	140	400	400	323	280	1091	3	M12	55	195	250	110	103	140	6-14
50×40 IFWM	90L	1.5	100	500	225	275	75	900	150	600	150	400	320	168.5	158.5	930	3	M12	55	195	250	110	115	140	6-14	
	2524	100L	2.2	100	500	225	275	75	900	150	600	150	400	320	193	173	969	3	M12	55	195	250	110	114	140	6-14
		112M	3.7	100	500	225	287	75	900	150	600	150	400	320	200	183	986	3	M12	55	195	250	110	115	140	6-14
	132S	5.5/7.5	100	500	225	275	75	995	170	660	165	400	400	239	210	1052	3	M12	55	195	250	110	123	140	6-14	
	160M	11.5	100	500	225	275	75	1120	190	740	190	440	440	323	280	1206	3	M12	55	195	250	110	136	140	6-14	
	160L	18.5	100	500	225	275	75	1120	190	740	190	440	440	345	302	1250	3	M12	55	195	250	110	136	160	8-14	
	180M	22	100	500	225	275	75	1120	190	740	190	440	440	351.5	325	1279.5	3	M12	55	195	250	110	133	160	8-14	
	180L	30	100	500	225	275	75	1260	205	840	215	490	490	370.5	344	1317.5	3	M12	55	195	250	110	153	180	8-14	
80×50 IFWM	71	0.4	100	385	180	240	60	725	115	480	130	320	250	120	121	729	3	M12	55	195	250	110	77	112	4-10	
	1313	80	0.75	100	385	180	240	60	725	115	480	130	320	250	140	133	761	3	M12	55	195	250	110	77	112	4-10
80×50 IFWM	90L	1.5	100	385	180	250	60	725	115	480	130	320	250	168.5	158.5	815	3	M12	55	195	250	110	78	112	4-10	
	1623	100L	2.2	100	385	180	240	60	765	130	540	95	320	320	193	173	854	3	M12	55	195	250	110	80	112	4-10
		112M	3.7	100	385	180	240	60	765	130	540	95	320	320	200	183	871	3	M12	55	195	250	110	80	112	4-10
	132S	5.5/7.5	100	385	180	240	60	805	130	540	135	350	350	239	210	937	3	M12	55	195	250	110	81	140	6-14	
	160M	11.5	100	385	180	255	60	970	170	660	140	400	400	323	280	1091	3	M12	55	195	250	110	98	140	6-14	
160L	18.5	100	385	180	255	60	970	170	660	140	400	400	345	302	1135	3	M12	55	195	250	110	103	160	8-14		

- Notes: 1. Motor output classification numbers shown are for ordinary E class totally-enclosed, fan-cooled low-voltage 3-phase squirrel-cage induction motors under JEM-1400-1983
 2. M₂ and LA dimensions marked with an asterisk vary to a certain extent, depending on motor manufacturers.
 3. Dimensions are subject to change without notice.
 4. In two motor ratings(kW) with slash mark, left side is the rating of four poles, right side is the rating of two poles.

Dimensions

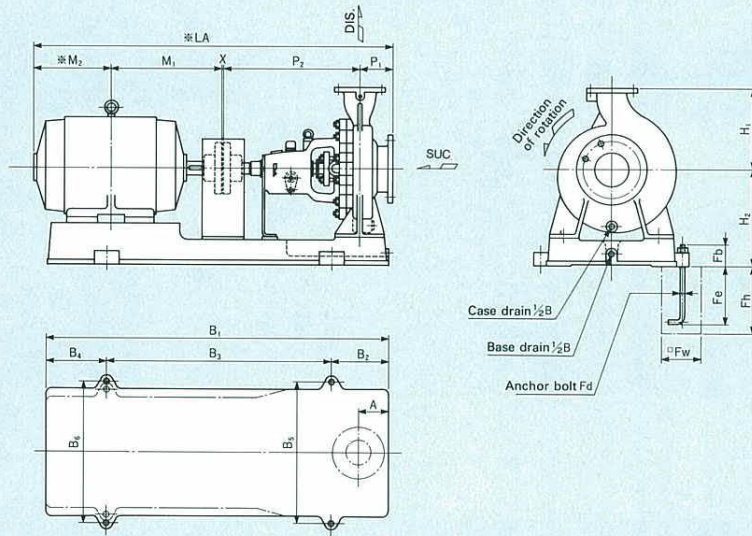

● Flange dimensions (JIS 10K, Regular flanges) for cast iron, cast steel and stainless steel pumps.

Unit: mm

Pump Model	Motor		Pump				Common base								Motor			Anchor bolt				Wt (kg)	Coupling		
	Frame	kW	P ₁	P ₂	H ₁	H ₂	A	B ₁	B ₂	B ₃	B ₄	B ₅	B ₆	M ₁	*M ₂	LA	X	Fd	Fb	Fe	Fh		Fw	CLA	CLAB
80×50 IFWM 2023	90L	1.5	100	385	200	250	60	725	115	480	130	320	250	168.5	158.5	815	3	M12	55	195	250	110	88	112	4-10
	100L	2.2	100	385	200	240	60	765	130	540	95	320	320	193	173	854	3	M12	55	195	250	110	90	112	4-10
	112M	3.7	100	385	200	240	60	765	130	540	95	320	320	200	183	871	3	M12	55	195	250	110	90	125	4-14
	132S	5.5	100	385	200	240	60	805	130	540	135	350	350	239	210	937	3	M12	55	195	250	110	89	140MB	6-14
	160M	11/15	100	385	200	255	60	970	170	660	140	400	400	323	280	1091	3	M12	55	195	250	110	108	140	6-14
	160L	18.5	100	385	200	255	60	970	170	660	140	400	400	345	302	1135	3	M12	55	195	250	110	113	160	8-14
	180M	22	100	385	200	275	60	1015	170	660	185	320	440	351.5	325	1164.5	3	M12	55	195	250	110	111	160	8-14
	180L	30	100	385	200	275	60	1015	170	660	185	320	440	370.5	344	1202.5	3	M12	55	195	250	110	111	180	8-14
80×50 IFWM 2524	90L	1.5	125	500	225	275	75	900	150	600	150	400	320	168.5	158.5	955	3	M12	55	195	250	110	122	140	6-14
	100L	2.2	125	500	225	275	75	900	150	600	150	400	320	193	173	994	3	M12	55	195	250	110	122	140	6-14
	112M	3.7	125	500	225	287	75	900	150	600	150	400	320	200	183	1011	3	M12	55	195	250	110	122	140	6-14
	132S	5.5	125	500	225	275	75	995	170	660	165	400	400	239	210	1077	3	M12	55	195	250	110	131	140	6-14
	132M	7.5	125	500	225	275	75	995	170	660	165	400	400	258	229	1115	3	M12	55	195	250	110	132	160	8-14
	160M	11/15	125	500	225	275	75	1120	190	740	190	440	440	323	280	1231	3	M12	55	195	250	110	144	140	6-14
	160L	18.5	125	500	225	275	75	1120	190	740	190	440	440	345	302	1275	3	M12	55	195	250	110	144	160	8-14
	180M	22	125	500	225	275	75	1120	190	740	190	440	440	351.5	325	1304.5	3	M12	55	195	250	110	141	160	8-14
	180L	30	125	500	225	275	75	1260	205	840	215	490	490	370.5	344	1342.5	3	M12	55	195	250	110	161	180	8-14
200L	37	125	500	225	295	75	1245	205	840	200	400	490	395.5	377	1400.5	3	M12	55	195	250	110	158	180	8-14	
80×50 IFWM 3214 (Only for 4P) 3224 (Only for 2P)	100L	2.2	125	500	280	320	75	905	150	600	155	400	320	193	173	994	3	M12	55	195	250	110	160	140	6-14
	112M	3.7	125	500	280	332	75	905	150	600	155	400	320	200	183	1011	3	M12	55	195	250	110	161	140	6-14
	132S	5.5	125	500	280	320	75	990	170	660	160	440	350	239	210	1077	3	M12	55	195	250	110	162	140	6-14
	132M	7.5	125	500	280	320	75	990	170	660	160	440	350	258	229	1115	3	M12	55	195	250	110	162	160	8-14
	160M	11/15	125	500	280	320	75	1120	190	740	190	440	440	323	280	1231	3	M12	55	195	250	110	175	160	8-14
	160L	18.5	125	500	280	320	75	1120	190	740	190	440	440	345	302	1275	3	M12	55	195	250	110	175	160	8-14
	180M	22	125	500	280	340	75	1120	190	740	190	440	440	351.5	325	1304.5	3	M12	55	195	250	110	177	160	8-14
	180L	30	125	500	280	320	75	1265	205	840	220	490	490	370.5	344	1342.5	3	M12	55	195	250	110	202	180	8-14
200L	37	125	500	280	320	75	1265	205	840	220	490	490	395.5	377	1400.5	3	M12	55	195	250	110	192	180	8-14	
100×80 IFWM 1314	90L	1.5	100	500	200	240	75	880	150	600	130	350	290	168.5	158.5	930	3	M12	55	195	250	110	100	140	6-14
	100L	2.2	100	500	200	240	75	880	150	600	130	350	290	193	173	969	3	M12	55	195	250	110	99	140	6-14
100×80 IFWM 1614	112M	3.7	100	500	200	240	75	900	150	600	150	350	200	183	986	3	M12	55	195	250	110	103	140	6-14	
	132S	5.5/7.5	100	500	200	255	75	970	170	660	140	400	400	239	210	1052	3	M12	55	195	250	110	160	140	6-14
	160M	11	100	500	200	255	75	1120	190	740	190	440	440	323	280	1206	3	M12	55	195	250	110	121	140	6-14
	160L	18.5	100	500	200	255	75	1120	190	740	190	440	440	345	302	1250	3	M12	55	195	250	110	121	160	8-14
	180M	22	100	500	200	275	75	1120	190	740	190	440	440	351.5	325	1279.5	3	M12	55	195	250	110	125	160	8-14
	180L	30	100	500	200	275	75	1245	205	840	200	400	490	370.5	344	1317.5	3	M12	55	195	250	110	143	180	8-14

- Notes: 1. Motor output classification numbers shown are for ordinary E class totally-enclosed, fan-cooled low-voltage 3-phase squirrel-cage induction motors under JEM-1400-1983
 2. M₂ and LA dimensions marked with an asterisk vary to a certain extent, depending on motor manufacturers.
 3. Dimensions are subject to change without notice.
 4. In two motor ratings(kW) with slash mark, left side is the rating of four poles, right side is the rating of two poles.

Dimensions



Unit : mm

Pump Model	Motor		Pump				Common base							Motor		*		Anchor bolt				Wt (Mass) kg	Coupling		
	Frame	kW	P ₁	P ₂	H ₁	H ₂	A	B ₁	B ₂	B ₃	B ₄	B ₅	B ₆	M ₁	*M ₂	LA	X	Fd	Fb	Fe	Fh		Fw	CLA	CLAB
200×150 IFWM	200L	35	160	670	450	450	110	1405	230	940	235	670	490	425.5	377	1636.5	4	M16	70	245	315	130	468	224	8-20
	3216	225S	55	160	670	450	455	110	1635	270	1060	305	670	432	388	1654	4	M16	70	245	315	130	520	224MB	8-20
200×150 IFWM	250S	75	160	670	450	430	110	1640	270	1060	310	670	670	463.5	501	1798.5	4	M16	70	245	315	130	517	250MB	8-25
	4026	250M	90	160	670	450	430	110	1640	270	1060	310	670	482.5	520	1836.5	4	M16	70	245	315	130	517	250MB	8-25
	280S	110	160	670	450	430	110	1640	270	1060	310	670	670	544	579	1957	4	M16	70	245	315	130	512	280MB	8-28
	280M	132	160	670	450	430	110	1640	270	1060	310	670	670	569.5	604.5	2008	4	M16	70	245	315	130	512	280MB	8-28
	315S	160	160	670	450	430	110	1670	300	1200	170	750	750	589	640	2063	4	M20	85	315	400	150	535	GEAR CP	
200×150 IFWM	250S	75	180	820	560	515	110	1840	300	1200	340	670	670	463.5	501	1968.5	4	M20	85	315	400	150	683	280	8-28
	5028	250M	90	180	820	560	515	110	1840	300	1200	340	670	482.5	520	2006.5	4	M20	85	315	400	150	683	280	8-28
	280S	110	180	820	560	490	110	1820	300	1200	320	670	670	544	579	2127	4	M20	85	315	400	150	684	280MB	8-28
	280M	132	180	820	560	490	110	1820	300	1200	320	670	670	569.5	604.5	2178	4	M20	85	315	400	150	684	280MB	8-28
	315S	160	180	820	560	490	110	2050	340	1320	390	750	750	589	640	2233	4	M20	85	315	400	150	701	GEAR CP	
	315M	200	180	820	560	490	110	2050	340	1320	390	750	750	614.5	665.5	2284	4	M20	85	315	400	150	701	GEAR CP	
250 IFWM	225S	55	225	695	560	490	170	1545	270	1060	215	750	550	432	388	1744	4	M20	85	315	400	150	631	224MB	8-20
	2516	250S	75	225	695	560	490	170	1650	270	1060	320	750	463.5	501	1888.5	4	M20	85	315	400	150	663	250MB	8-25
	250M	90	225	695	560	490	170	1650	270	1060	320	750	750	482.5	520	1926.5	4	M20	85	315	400	150	663	250MB	8-25
	280S	110	225	695	560	490	170	1850	300	1200	350	750	750	544	579	2047	4	M20	85	315	400	150	697	280MB	8-28
	280M	132	225	695	560	490	170	1850	300	1200	350	750	750	569.5	604.5	2098	4	M20	85	315	400	150	697	280MB	8-28
	315S	160	225	695	560	490	170	1850	300	1200	350	750	750	589	640	2153	4	M20	85	315	400	150	730	GEAR CP	
250×200 IFWM	250S	75	180	670	560	490	170	1650	270	1060	320	750	750	463.5	501	1818.5	4	M20	85	315	400	150	622	250MB	8-25
	3216	250M	90	180	670	560	490	170	1650	270	1060	320	750	482.5	520	1856.5	4	M20	85	315	400	150	622	250MB	8-25
	280S	110	180	670	560	520	170	1650	270	1060	320	750	750	544	579	1977	4	M20	85	315	400	150	645	280MB	8-28
250×200 IFWM	4016	280M	132	180	670	560	490	170	1850	300	1200	350	750	569.5	604.5	2028	4	M20	85	315	400	150	683	280MB	8-28
	315S	160	180	670	560	490	170	1850	300	1200	350	750	750	589	640	2083	4	M20	85	315	400	150	690	GEAR CP	
	315M	200	180	670	560	490	170	1850	300	1200	350	750	750	614.5	665.5	2134	4	M20	85	315	400	150	690	GEAR CP	
250×200 IFWM	280M	132	200	820	630	540	170	2120	340	1320	460	750	750	569.5	604.5	2198	4	M20	85	315	400	150	859	280MB	8-28
	5028	315S	160	200	820	630	575	170	2120	340	1320	460	750	589	640	2253	4	M20	85	315	400	150	871	GEAR CP	
	315M	200	200	820	630	575	170	2120	340	1320	460	750	750	614.5	665.5	2304	4	M20	85	315	400	150	871	GEAR CP	

- Notes: 1. Motor output classification numbers shown are for ordinary E class totally-enclosed, fan-cooled low-voltage 3-phase squirrel-cage induction motors under JEM-1400-1983
 2. M₂ and LA dimensions marked with an asterisk vary to a certain extent, depending on motor manufacturers.
 3. Dimensions are subject to change without notice.



EBARA CORPORATION

Head Office:

11-1, Haneda Asahi-cho, Ohta-ku,
Tokyo, 144-8510 Japan
Phone: 81-3-3743-6111
Fax: 81-3-3745-3356
Internet homepage : <http://www.ebara.co.jp>

Sales headquarter:

1-6-27, Konan, Minato-ku, Tokyo,
108-8480, Japan
Phone: 81-3-5461-6101
Fax: 81-3-5976-0415

Please send your enquiries to the above International Division

○: Liaison Offices

AMERICA**UNITED STATES OF AMERICA**

Ebara International Corporation (Sparks, NV)
Airvac, Inc. (Rochester, IN)
Elliott Turbomachinery Co., Inc. (Jeannette, PA)

BRAZIL

Ebara Indústrias Mecânicas e Comércio Ltda.
(Bauru, S.P.)

EUROPE**ENGLAND**

Elliott Turbomachinery Limited (Basingstoke)

ITALY

- Italy Office (Vicenza)
- Ebara Pumps Europe S.p.A. (Trento)
- Sumoto S.r.l. (Vicenza)

SPAIN

Ebara Espana Bombas S.A. (Madrid)

ASIA**PEOPLE'S REPUBLIC OF CHINA**

- Beijing Office (Beijing)
- Yantai Ebara Air Conditioning Equipment Co., Ltd.
(Yantai)
- Beijing Ebara Machinery Co., Ltd. (Beijing)
- Ebara Machinery (Shanghai) Co., Ltd. (Shanghai)
- Shanghai Ebara Engineering and Services Co., Ltd.
(Shanghai)
- Ebara Qingdao Co., Ltd. (Qingdao)
- Ebara Densan (Kunshan) Mfg. Co., Ltd. (Kunshan)

TAIWAN

- Taipei Office (Taipei)
- Ebara-Densan Taiwan Manufacturing Co., Ltd.
(Chung Li)
- Ebara-Elliott Service (Taiwan) Co., Ltd. (Taichung)
- Ebara Kailay Environmental Engineering Co., Ltd.
(Taipei)

KOREA

Hyosung-Ebara Co., Ltd. (Seoul)
Hyosung-Ebara Environment Engineering Co., Ltd.
(Seoul)

SINGAPORE

- Singapore Office (Singapore)
- Ebara Engineering Singapore Pte. Ltd.
(Singapore)

MALAYSIA

Ebara Pumps Malaysia Sdn. Bhd (Selangor)
Ebara Environmental Engineering (Malaysia) Sdn. Bhd.
(Selangor)

PHILIPPINES

- Manila Branch Office (Manila)
- Ebara Benguet, Inc. (Laguna)

VIETNAM

Ebara Hai Duong Company Ltd. (Hai Duong)
Ebara Vietnam Corporation (Hanoi)

THAILAND

- Bangkok Office (Bangkok)
- Ebara (Thailand) Limited (Bangkok)

INDIA

EBARA Machinery India Pvt. Ltd. (Chennai)

MIDDLE-EAST**United Arab Emirates**

- Middle East Office (Dubai)

OCEANIA**AUSTRALIA**

Ebara Pumps Australia Pty. Ltd. (Bayswater, Vic)